



US007193588B2

(12) **United States Patent**
Lo

(10) **Patent No.:** **US 7,193,588 B2**
(45) **Date of Patent:** **Mar. 20, 2007**

(54) **ACTIVE MATRIX ORGANIC ELECTROLUMINESCENCE DISPLAY DRIVING CIRCUIT**

6,501,466	B1*	12/2002	Yamagishi et al.	345/204
6,747,638	B2*	6/2004	Yamazaki et al.	345/207
6,753,655	B2*	6/2004	Shih et al.	315/169.3
6,778,151	B2*	8/2004	Li	345/55
2003/0067424	A1*	4/2003	Akimoto et al.	345/55

(75) Inventor: **Shin-Tai Lo**, Miaoli (TW)

(73) Assignee: **Wintek Corporation**, Taichung (TW)

(*) Notice: Subject to any disclaimer, the term of this patent is extended or adjusted under 35 U.S.C. 154(b) by 635 days.

(21) Appl. No.: **10/671,452**

(22) Filed: **Sep. 29, 2003**

(65) **Prior Publication Data**
US 2005/0068271 A1 Mar. 31, 2005

(51) **Int. Cl.**
G09G 3/30 (2006.01)

(52) **U.S. Cl.** **345/76; 345/55; 345/82;**
315/169.1

(58) **Field of Classification Search** 345/76,
345/82, 55, 92; 315/169.1, 169.3, 169.4;
340/815.45

See application file for complete search history.

(56) **References Cited**

U.S. PATENT DOCUMENTS

6,229,506	B1*	5/2001	Dawson et al.	345/82
6,373,454	B1*	4/2002	Knapp et al.	345/76

OTHER PUBLICATIONS

D. Fish et al: SID 02 Digest, 32.1: Invited Paper, (2002) pp. 968-971.

* cited by examiner

Primary Examiner—Richard Hjerpe

Assistant Examiner—Kimmhung Nguyen

(74) *Attorney, Agent, or Firm*—Birch, Stewart, Kolasch and Birch, LLP

(57) **ABSTRACT**

A driving circuit of active matrix organic electroluminescence display is disclosed. Each pixel includes four TFTS and two capacitors. A gate of scan TFT is controlled by the scan line of the row where the pixel is located and a drain of scan TFT is connected to the data line of the column where the pixel is situated. Reset TFT and detect TFT are controlled by one threshold-lock line. One capacitor Cd is used to store data voltage (Vdata) of image signals and the other capacitor Ct is used to store threshold voltage (Vth) of drive TFT. Therefore, the sum of capacitors Cd and Ct will drive TFT to output a corresponding current to the organic electro luminescence element.

5 Claims, 6 Drawing Sheets

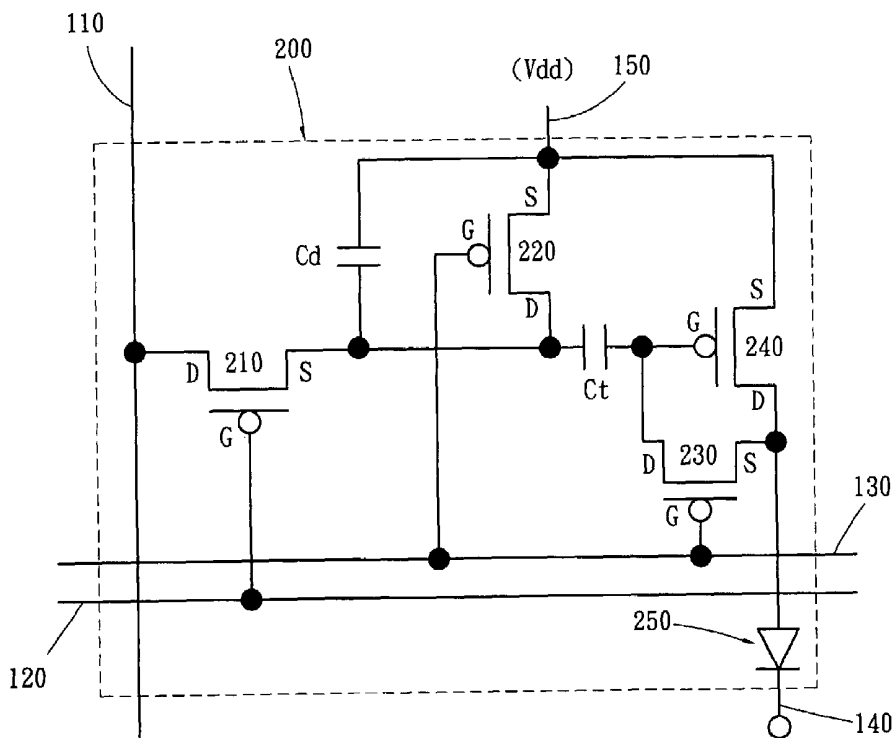

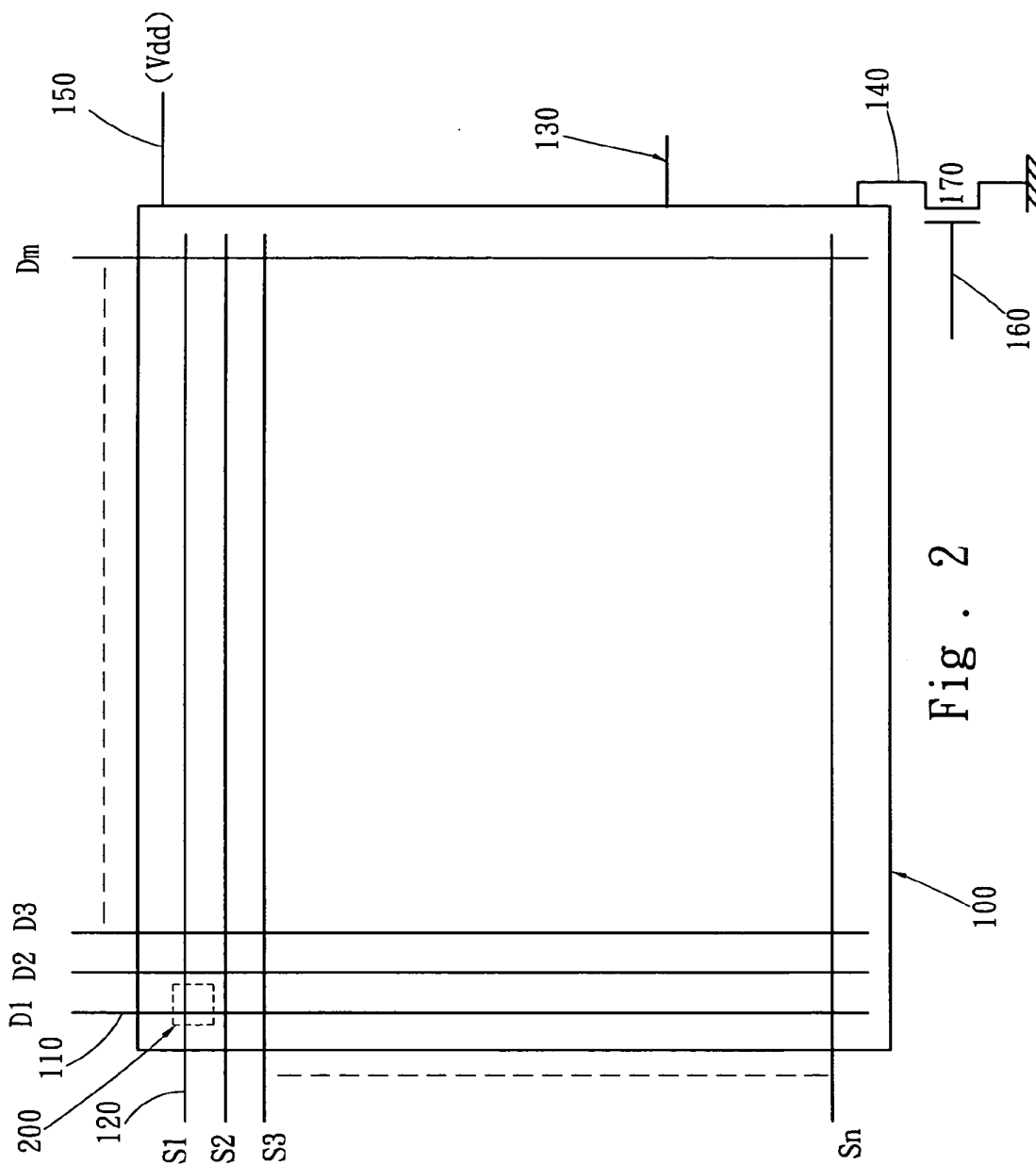

Fig. 2

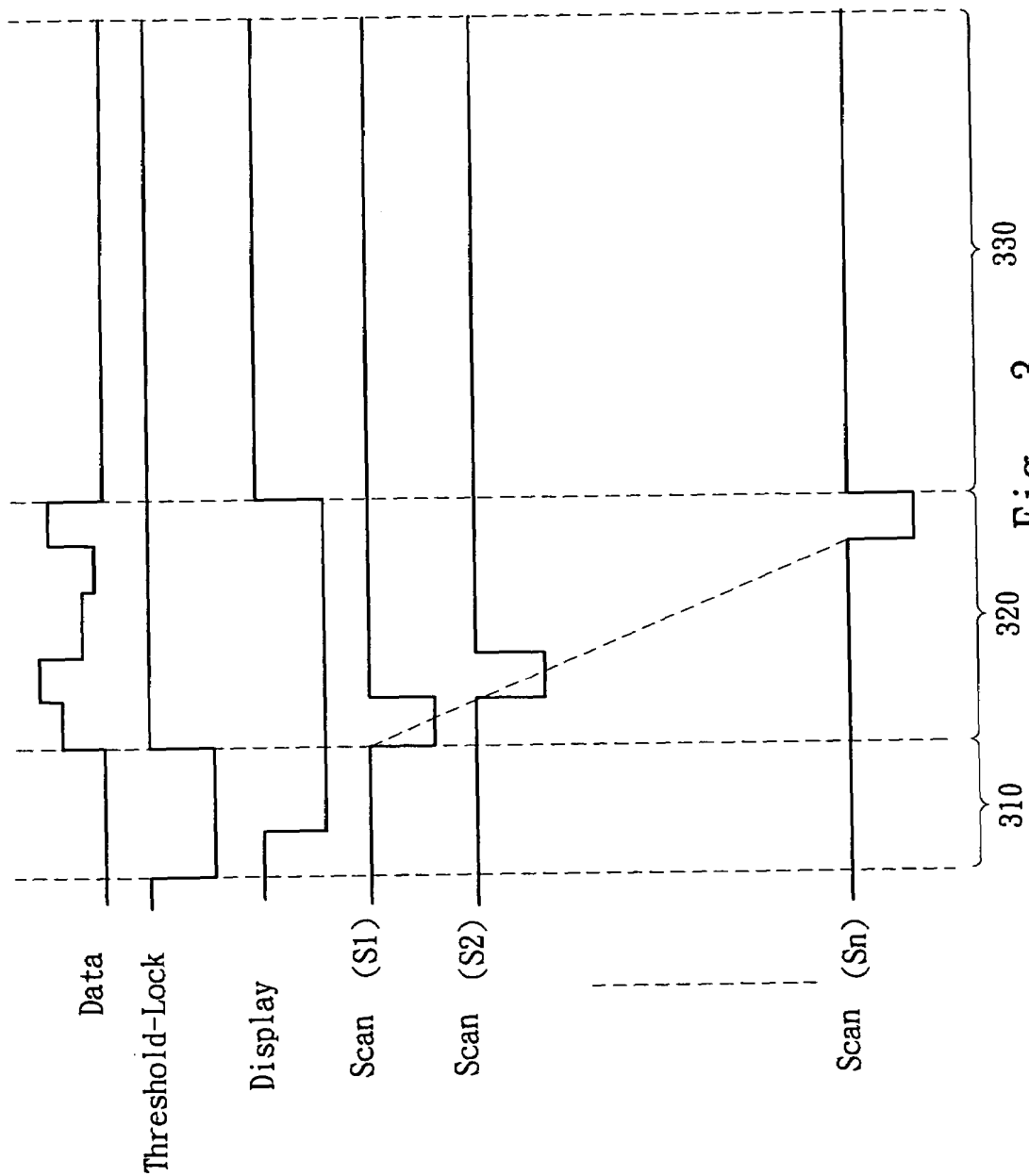

Fig. 3

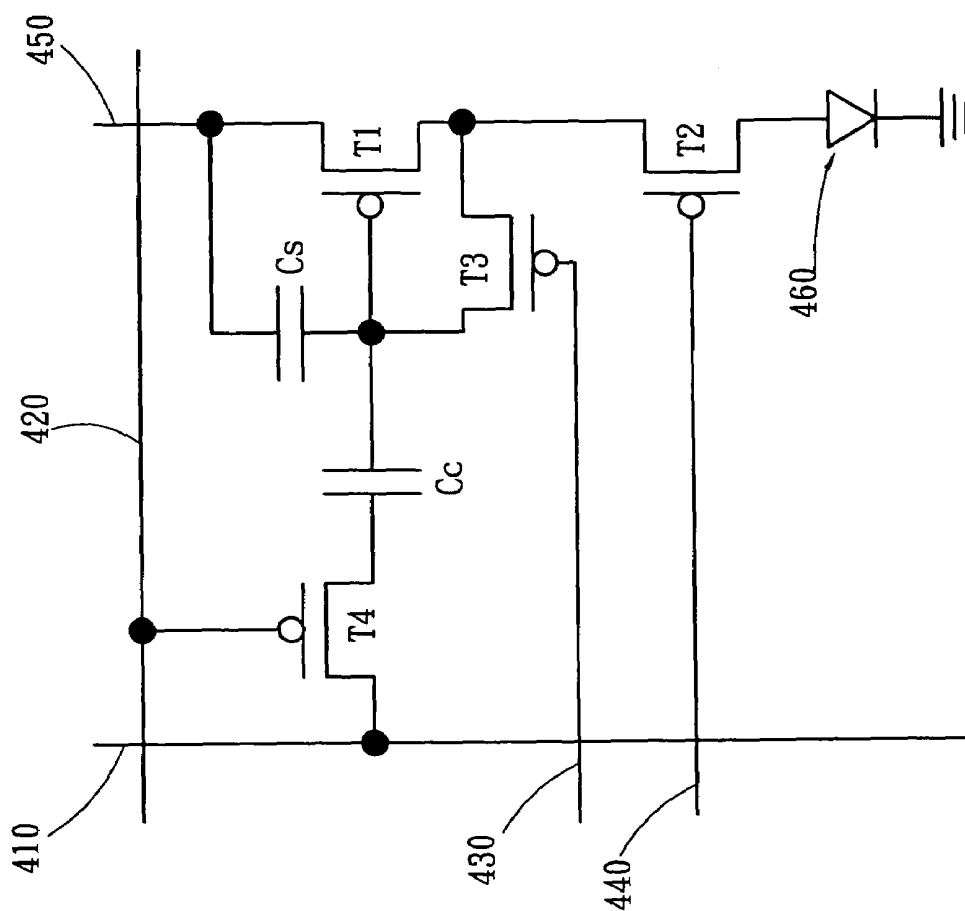

Fig. 4
PRIOR ART

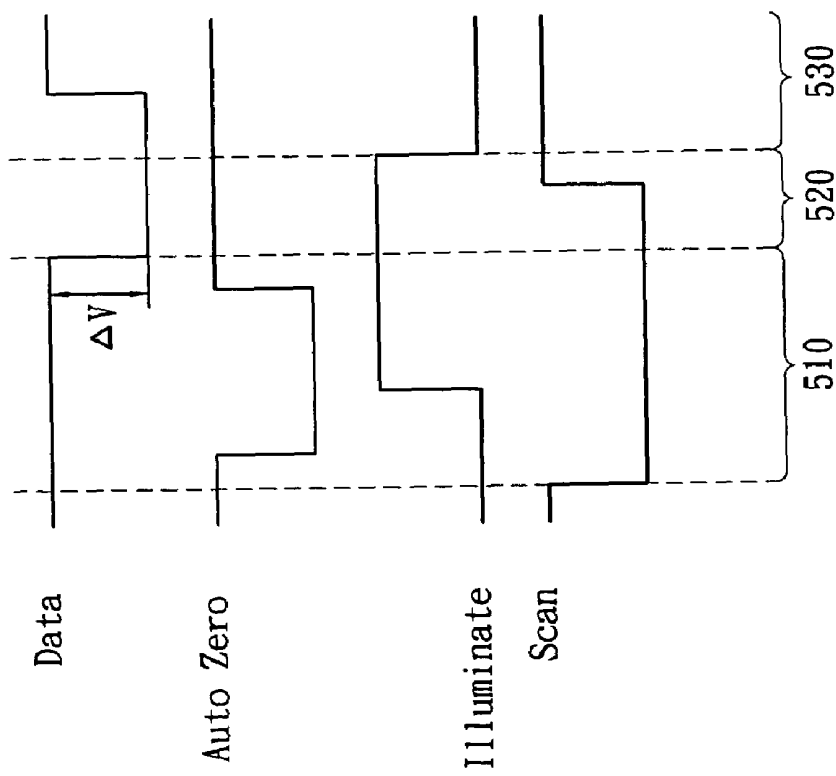

Fig. 5
PRIOR ART

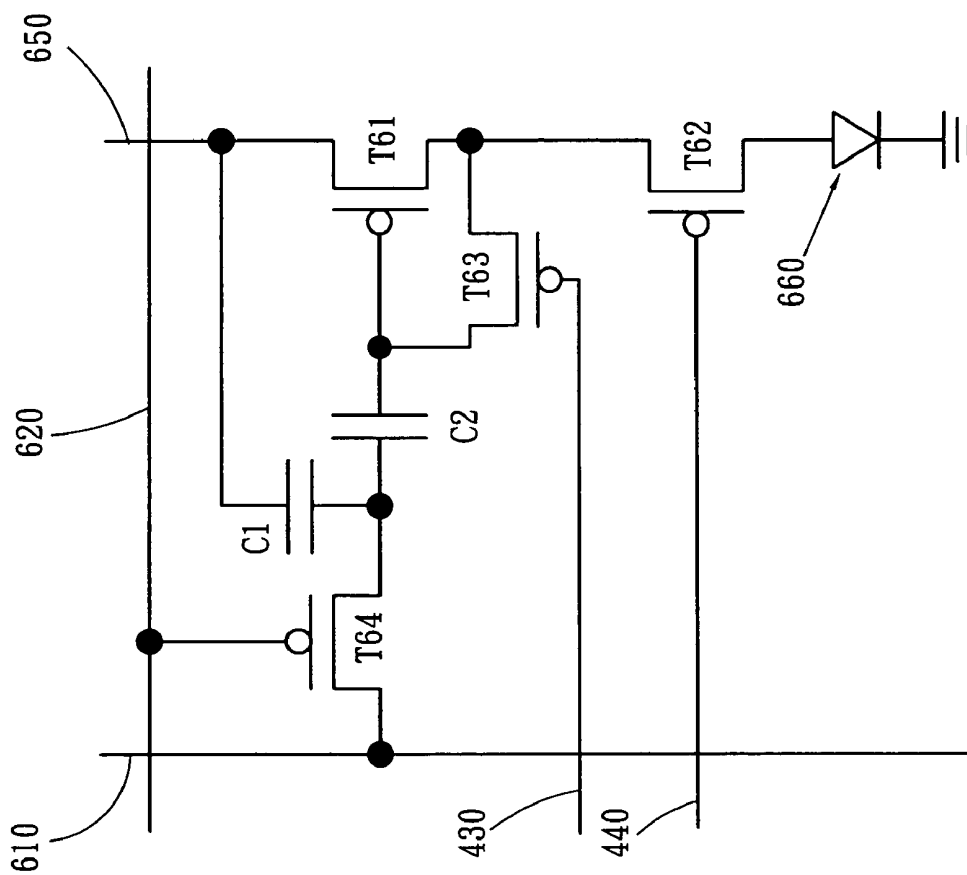

Fig. 6
PRIOR ART

**ACTIVE MATRIX ORGANIC
ELECTROLUMINESCENCE DISPLAY
DRIVING CIRCUIT**

FIELD OF THE INVENTION

This invention relates to a driving circuit of active matrix organic electroluminescence display. More particularly, the invention is directed to a driving device and method that improve the non-uniform phenomena on an active matrix organic light-emitting diode display panel.

BACKGROUND OF THE INVENTION

OLED Display can be classified according to its driving method, passive-matrix (PMOLED) and active-matrix (AMOLED). AMOLED uses TFT (Thin Film Transistor) with a capacitor for storing data signals that can control OLED levels of brightness.

Manufacturing procedure of PMOLED is simpler in comparison and is less costly of the two; however, it is limited in its size (<5 inch) because of its driving mode and has a lower-resolution display application. In order to produce an OLED display with higher resolution and larger size, utilizing active-matrix driving is necessary. The so-called AMOLED uses TFT (Thin Film Transistor) with a capacitor for storing data signals, so that pixels can maintain its brightness after line scanning; on the other hand, pixels of passive matrix driving only light up when scan line selects them. Therefore, with active matrix driving, the brightness of OLED is not necessarily ultra-bright, resulting in longer lifetime, higher efficiency and higher resolution. Naturally, TFT-OLED with active matrix driving is suitable for display application of higher resolution and excellent picture due to the unique qualities of OLED.

LTPS (Low Temperature Poly-Silicon) and a-Si (amorphous Silicon) are both technologies of TFT integrating on glass substrate. The obvious differences are electric characteristics and complexity of process. Although LTPS-TFT possesses higher carrier mobility and higher mobility means more current can be supplied, the process is much more complex. However, the process of a-Si TFT is simpler and maturer, except for low carrier mobility. Therefore, a-Si process has better competitive advantages in cost.

Due to limitations of LTPS process capability, threshold voltage and mobility of TFT elements produced vary leading to different properties of each TFT element. When the driving system achieves gray scale by analog voltage modulation, OLED produces different output current despite of the same data voltage signal input due to different TFT characteristics of various pixels. Therefore, luminance of OLED varies. Images of erroneous gray scale will show up on OLED panel and damage image uniformity seriously.

The most urgent problem of AMOLED to be solved currently is how to reduce bad impact of uneven LTPS-TFT characteristics. Such issue requires immediate solution for follow-up development and application since images on the display tell the difference.

U.S. Pat. No. 6,229,506 discloses an Active Matrix Light Emitting Diode Pixel Structure And Concomitant Method. A 4T2C (4 TFTS and 2 capacitors) pixel circuit is proposed as shown in FIG. 4. An Auto-Zero mechanism is applied to compensate for the threshold voltage differences of TFT elements to improve uniformity of images. Driving sequences of control signals include Auto-Zero Phase 510, Load Data Phase 520 and Illuminate Phase 530. Refer to FIG. 5 for the sequences of control signals in FIG. 4.

Transistors T3 and T4 are off and Transistor T2 is on prior to Auto-Zero Phase 510. The current passing through OLED 460 at this moment is current of the previous frame and controlled by Vsg of Transistor T1 (voltage difference between source and gate; i.e., voltage difference of both ends of Cs).

After entering Auto-Zero Phase 510, Transistor T4 is on and then Transistor T3 is on, too so that Drain and Gate of Transistor T1 can be connected as a diode. As Transistor T2 is off, gate voltage of Transistor T1 will increase, which equals to Vdd minus threshold voltage (Vth) of Transistor T1. That is to say, the voltage difference stored at both ends of capacitor Cs is the threshold voltage of Transistor T1. After placing Transistor T3 off, threshold voltage (Vth) of Transistor T1 can be stored into capacitor Cs and Auto-Zero Phase 510 is completed.

On Load Data Phase 520, when voltage difference of Data Line 410 is ΔV , it can couple to the gate of Transistor T1 through Transistor T4 and capacitor Cc. Thus, voltage difference stored at both ends of capacitor Cs will be $\Delta V \times [C_c / (C_c + C_s)]$ adding Vth that is stored in capacitor Cs previously. That is, Vsg of Transistor T1 includes Vth of Transistor T1, which makes output current of Transistor T1 relate to voltage change (ΔV) of Data Line 410 only, instead of being affected by Vth of transistor in every pixel.

Last when Illuminate Phase 530 begins, Transistor T4 is off and Transistor T2 is on. Output current of Transistor T1 at the present frame will flow through OLED 460 to illuminate.

Though this 4T2C pixel circuit may compensate for the threshold voltage (Vth) differences of transistor elements in each pixel and improve integral uniformity of images; however, other control lines like Auto-Zero Line 430 and Illuminate Line 440 are required in addition to Data Line 410, Scan Line 420 and Supply Line (Vdd) 450. Capacitor Cs has to record all threshold voltages and part of data voltages loaded. Besides, capacitance coupling approach is used to load data, which not only makes driving method more complicated, but also increases manufacturing cost when non-standard data driving IC is required.

To solve the same problem, Philips also published a thesis with the subject of A Comparison of Pixel Circuits for Active Matrix Polymer/Organic LED Displays. One 4T2C pixel circuit is presented in the thesis as FIG. 6 shows. It skillfully changes the location of connecting two capacitors in the pixel circuit of the U.S. Pat. No. 6,229,506 (FIG. 4) to solve the defects causing by complexity and impracticability. However, control lines like Auto-Zero Line 630 and Illuminate Line 640 are also required in addition to Data Line 610, Scan Line 620 and Supply Line (Vdd) 650.

The sequences of driving control signals are the same as the U.S. Pat. No. 6,229,506 since they consist of Auto-Zero Phase 510, Load Data Phase 520 and Illuminate Phase 530. Please refer to FIG. 5 and the sequences of control signals in FIG. 6.

On Auto-Zero Phase 510, Transistor T64 is off and then Transistor T63 is on so that Drain and Gate of Transistor T61 can be connected as a diode. As Transistor T62 is off, gate voltage of Transistor T61 will increase, which equals to Vdd minus threshold voltage (Vth) of Transistor T61. That is to say, the sum of voltage stored at capacitors C1 and C2 is the threshold voltage (Vth) of Transistor T61. After placing Transistor T63 off, Auto-Zero Phase 510 is completed.

Data voltage is conducted through connection of Transistor T64. Data voltage is stored in Capacitor C1 and a certain proportion of Vth previously stored at both ends of Capacitor C2 is still maintained, which equals to $[C_1 / (C_1 + C_2)] \times$

V_{th} . Thus, the sum of capacitors **C1** and **C2** is $(V_{dd}-V_{data}+[C1/(C1+C2)]\times V_{th})$; i.e., V_{sg} of Transistor **T61** contains part of V_{th} of Transistor **T61**, which may not only reduce the correlation between the output current and threshold voltage of Transistor **T61**, but also compensate for part of the threshold voltage (V_{th}) difference resulted from process factors. The threshold voltage of Transistor **T61** in the thesis is memorized by two capacitors (**C1** & **C2**). Part of threshold voltage data stored in one of the capacitors will get lost while loading data voltage. Therefore, this approach can only make up for part of threshold voltage difference resulted from process.

SUMMARY OF THE INVENTION

The main purpose of this invention is to solve the aforementioned problems existed for a long time. As the critical component parts of AMOLED like TFT-OLED Data IC are not well developed, the well developed technology of TFT-LCD Source IC can be applied to support TFT-OLED application. However, TFT-LCD Source IC adopts voltage modulation; thus, design of a voltage driving circuit is required.

Hence, a voltage type of AMOLED driving circuit that can compensate for TFT threshold voltage variations is presented in this invention so as to improve image defects resulted from uneven characteristics of TFT.

To achieve the objective above, a driving device of each pixel presented in this invention includes 4 TFTs and 2 capacitors, which are 1 scan TFT, 1 reset TFT, 1 detect TFT, 1 drive TFT, 2 capacitors (**Cd** & **Ct**) and 1 organic electro-luminescence element. The gate of scan TFT is controlled by the scan line of the row where the pixel is located and the drain of scan TFT is connected to the data line of the column where the pixel is situated. Reset TFT and detect TFT are controlled by one threshold-lock line. Capacitor **Cd** is used to store data voltage (V_{data}) of image signals and capacitor **Ct** is used to store threshold voltage (V_{th}) of Drive TFT. Therefore, the sum of voltage stored in capacitors **Cd** and **Ct** will force Drive TFT to output an corresponding current to the organic electro luminescence element.

BRIEF DESCRIPTION OF THE DRAWINGS

FIG. 1 is the circuit of each pixel in this invention.

FIG. 2 is the connection and control of a pixel circuit in this invention.

FIG. 3 is the sequences of control signals in this invention.

FIG. 4 is a schematic pixel circuit diagram of U.S. Pat. No. 6,229,506.

FIG. 5 is a schematic diagram of control signal time sequence of U.S. Pat. No. 6,229,506.

FIG. 6 is the circuit of pixel in a thesis published by PHILIPS.

DETAILED DESCRIPTION OF THE PREFERRED EMBODIMENTS

Refer to FIG. 1 for the circuit of each pixel in this invention. As the Figure shows: the driving circuit of pixel **200** includes 4 TFTs and 2 capacitors connected as follows:

Gate of a Scan TFT **210** connected to one Scan Line **120** and drain connected to a Data Line **110**.

Gate of a Reset TFT **220** connected to a Threshold-Lock **130**, source connected to a Supply Line **150** and drain connected to source of Scan TFT **210**.

Two ends of Capacitor **Cd** installed between source of Scan TFT **210** and source of Reset TFT **220**.

Source of Drive TFT **240** connected to Supply Line **150**.

Gate of Detect TFT **230** connected to Threshold-Lock **130**, drain connected to the gate of Drive TFT **240** and source connected to the drain of Drive TFT **240**.

Two ends of Capacitor **Ct** installed between drain of Reset TFT **220** and gate of Drive TFT **240**.

Anode of an organic electro luminescence element **250** connected to the drain of Drive TFT **240** and cathode connected to a Common Line **140**.

Refer to FIG. 2 for connection and control of a pixel circuit in this invention. As the Figure shows: a joint where a scan line **120** (**S1**, **S2**, **S3** . . . **Sn**) and a data line **110** (**D1**, **D2**, **D3** . . . **Dm**) meet is a pixel **200**. Refer to FIG. 1, FIG. 2. The gate of Scan TFT **210** is controlled by Scan Line **120** of the row where Pixel **200** is located, and the drain of Scan TFT **210** is connected to Data Line **110** of the column where Pixel **200** is situated. Reset TFT **220** and Detect TFT **230** are controlled by Threshold-Lock **130**. Capacitor **Cd** is used to store data voltage (V_{data}) of image signals and Capacitor **Ct** is used to store threshold voltage (V_{th}) of Drive TFT **240**. Therefore, the sum of voltage stored in capacitors **Cd** and **Ct** will force Drive TFT **240** for an output of corresponding current to the organic electro luminescence element **250**.

Reset TFT **220** and Detect TFT **230** of each Pixel **200** circuit on Display Substrate **100** are controlled by the same Threshold-Lock **130** and cathode of organic electro luminescence element **250** in every Pixel **200** is jointly connected to a Common Line **140**, which is connected to the grounding end of the system via an external switch **170** controlled by a display signal line **160**. Source of Drive TFT **240** in each Pixel **200** circuit is jointly connected to a supply line (V_{dd}) **150**.

Actuation procedures of this invention are described as follows:

Refer to FIG. 3 for the sequences of control signals in this invention. A cycle of driving signals can be divided into three phases. First, Threshold-Lock Phase **310**:

Signals of Threshold-Lock **130** will trigger Reset TFT **220** and Detect TFT **230** in every pixel circuit on. When Reset TFT **220** is on, Capacitor **Cd** storing voltage of image data will discharge. Display Signal Line **160** controls Switch **170** outside of Substrate **100** and makes it off. Thus, an open circuit exists between Common Line **140** and the grounding end of the system. Current of Drive TFT **240** stops flowing through organic electro luminescence element **250**, but through Detect TFT **230** that is on at this moment, which forces Drive TFT **240** to detect threshold voltage. As current of Drive TFT **240** passes by Detect TFT **230**, Capacitor **Ct** and Reset TFT **220**, voltage stored in Capacitor **Ct** becomes smaller and smaller, which also makes current of Drive TFT **240** become smaller until no current is left.

At last, Capacitor **Cd** won't store any electric charge (0 voltage on both ends) and voltage difference on both ends of Capacitor **Ct** will equal to threshold voltage (V_{th}) of Drive TFT **240**; i.e. when Capacitor **Cd** discharges and resets, Capacitor **Ct** will memorize threshold voltage (Refer to FIG. 1 for Pixel **200** circuit.). In summary, threshold voltage (V_{th}) of Drive TFT **240** in every Pixel **200** circuit will be stored in its own Capacitor **Ct** after Threshold-Lock Phase **310**.

Next, signals of Threshold-Lock **130** will trigger Reset TFT **220** and Detect TFT **230** in every Pixel **200** circuit off for the following Write Phase **320**.

In Write Phase **320**, each Scan Line **120** (**S1**, **S2** . . . **Sn**) will send out scan signals in order. When scan signals shift to Scan Line **120**, all Scan TFT **210** on the same scan line

will be on and Reset TFT **220** and Detect TFT **230** will be off. Data voltage (Vdata) of Data Line **110** can be stored into Capacitor Cd as Scan TFT **210** is on; however, threshold voltage (Vth) previously memorized by Capacitor Ct will still be retained as Reset TFT **220** and Detect TFT **230** are off. Thus, voltage difference between two ends of Capacitor Cd will be equivalent to supply voltage (Vdd) minus data voltage (Vdata); i.e. voltage at both ends of Capacitor Cd is (Vdd-Vdata).

Therefore, the sum of voltage stored in capacitors Cd and Ct will equal to (Vdd-Vdata+Vth), which will enable Drive TFT **240** to output corresponding current to organic electro luminescence element **250** in the following phase (Display Phase **330**). Consequently, the current (I) can be expressed with a formula as follows:

$$I=(\frac{1}{2})\times\hat{\alpha}\times(V_{sg}-V_{th})^2$$

$$I=(\frac{1}{2})\times\hat{\alpha}\times(V_{dd}-V_{data}+V_{th})^2$$

$$I=(\frac{1}{2})\times\hat{\alpha}\times(V_{dd}-V_{data})^2$$

From the above equations ($\hat{\alpha}$ is the Transconductance Parameter of Drive TFT **240**), the current (I) generated by Drive TFT **240** is irrelevant to the threshold voltage (Vth) of its own, but only correlated to write data voltage (Vdata). Thus, threshold voltage differences of TFT resulted from process factors can be compensated.

When the last Scan Line **120** (Sn) completes writing data voltage (Vdata), Display Signal Line **160** will control Switch **170** and make it on and Common Line **140** will be connected to the grounding end of the system for the third stage of Display Phase **330**.

In Display Phase **330**, Drive TFT **240** in each Pixel **200** circuit will output Current (I) related to written data voltage (Vdata) to organic electro luminescence element **250**, which produces proper luminance. Output Current (I) is not related to threshold voltage (Vth) of Drive TFT **240**.

In comparison with the U.S. Pat. No. 6,229,506, the technology of loading data voltage realized in this invention can be applied to TFT-LCD Source IC (Voltage Mode) that is popular currently and avoids complexity.

To compare with the thesis published by PHILIPS with the subject of A Comparison of Pixel Circuits for Active Matrix Polymer/Organic LED Displays, the technology of this invention is to record all threshold voltage into one capacitor (capacitor Ct) to offset the effect of threshold voltage differences.

Furthermore, as the critical component parts of AMOLED like TFT-OLED Data IC are not well developed at present, the well-developed technology of TFT-LCD Source IC is required to support TFT-OLED application. However, TFT-LCD Source IC adopts voltage modulation; thus, design of a voltage driving circuit is required.

Two capacitors (Cd & Ct) are used in this invention to deal with two different things. One capacitor Ct is responsible to record all threshold voltage values (Vth) and the other capacitor Cd is in charge of recording all data voltage values (Vdata). It is different from U.S. Pat. No. 6,229,506

as the capacitor Cs has to record all threshold voltage (Vth) and part of data voltage (Vdata) loaded. It is also different from the thesis released by PHILIPS as capacitors C1 and C2 record threshold voltage jointly. Part of threshold voltage stored in Capacitor C1 will be lost since Capacitor C2 only records part of threshold voltage.

To conclude, the AMOLED driving circuit of this invention has the following advantages:

1. As all threshold voltage values (Vth) can be stored in one capacitor Ct (threshold voltage storage capacitor), the effects of threshold voltage differences can be compensated completely.

2. The technology of loading data voltage (Vdata) realized in this invention can be achieved by TFT-LCD Source IC (Voltage Mode) that is popular currently and avoids complexity.

What is claimed is:

1. A driving circuit of active matrix organic electroluminescence display is disclosed and a driving circuit of each pixel on a display panel includes:

a scan TFT, the gate of the Scan TFT connected to a Scan Line and drain connected to a Data Line;

a reset TFT, the gate of the Reset TFT connected to a Threshold-Lock, source connected to a Supply Line and drain connected to source of the Scan TFT;

a capacitor Cd, having two ends installed between source of the Scan TFT and source of the Reset TFT;

a drive TFT, the source of the Drive TFT connected to the Supply Line;

a detect TFT, the gate of the Detect TFT connected to the Threshold-Lock, drain connected to the gate of the Drive TFT and source connected to the drain of the Drive TFT;

a capacitor Ct, having two ends installed between the drain of the Reset TFT and the gate of Drive TFT;

an organic electroluminescence element, the anode of the organic electroluminescence element connected to the drain of the Drive TFT and cathode connected to a Common Line;

a switch on the display panel is used to connect the Common Line and the grounding end.

2. The driving circuit of active matrix organic electroluminescence display according to claim 1, wherein the Reset TFT and Detect TFT of each pixel circuit on a display substrate are controlled by the same Threshold-Lock.

3. The driving circuit of active matrix organic electroluminescence display according to claim 1, wherein the cathode of organic electroluminescence element in every pixel circuit is jointly connected to a Common Line.

4. The driving circuit of active matrix organic electroluminescence display according to claim 1, wherein the switch is a thin film transistor (TFT).

5. The driving circuit of active matrix organic electroluminescence display according to claim 1, wherein the switch is controlled by a Display Signal Line.

* * * * *

专利名称(译)	有源矩阵有机电致发光显示驱动电路		
公开(公告)号	US7193588	公开(公告)日	2007-03-20
申请号	US10/671452	申请日	2003-09-29
[标]申请(专利权)人(译)	LO SHIN TAI		
申请(专利权)人(译)	LO SHIN-TAI		
当前申请(专利权)人(译)	胜华科技股份有限公司		
[标]发明人	LO SHIN TAI		
发明人	LO, SHIN-TAI		
IPC分类号	G09G3/30 G09G3/32		
CPC分类号	G09G3/3233 G09G2300/0819 G09G2300/0852 G09G2310/0251 G09G2320/043 G09G2300/0842		
其他公开文献	US20050068271A1		
外部链接	Espacenet	USPTO	

摘要(译)

公开了一种有源矩阵有机电致发光显示器的驱动电路。每个像素包括四个TFTS和两个电容器。扫描TFT的栅极由像素所在的行的扫描线控制，扫描TFT的漏极连接到像素所在的数据线。复位TFT和检测TFT由一个阈值锁定线控制。一个电容器Cd用于存储图像信号的数据电压 (Vdata)，另一个电容器Ct用于存储驱动TFT的阈值电压 (Vth)。因此，电容器Cd和Ct之和将驱动TFT以向有机电致发光元件输出相应的电流。

